



LUNOCOS

LEKANI 100

LED High Bay Light

- 185lm/w and CRI>80 IP65 IK08.
- ERP class A maximum energy savings
- Beam Angle: 90°
- Specially designed driver with 6KV surge protection.
- Professional high light efficiency high power 5050 LED applications
- ENEC Certificate
- 5 years warranty
- Widely used in workshops, warehouses, exhibition halls, gymnasiums, logistics centers, waiting rooms, stations, and high-bay workshops.

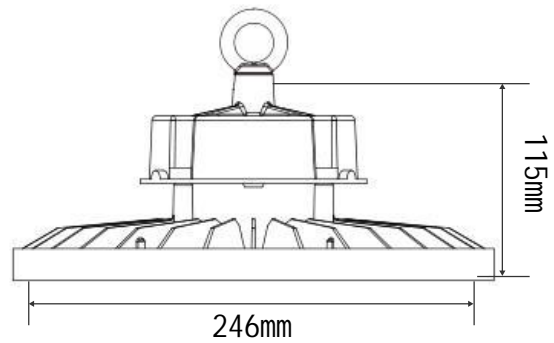

Specification | Technical & Product Data:

LED TYPE	SMD 2835
Wattage	100 W
Frequency	50-60 HZ
Power Factor	>0.95
Beam Angle	90°
Color Temperature	4000 K
SDCM	<6
Light efficiency	typ. 185 lm/W
Luminous flux	typ. 18500 lm
CRI	>80
Size	246 * 115mm
Lifespan L80/B10	100000 hrs at 35 °C
IP rate	IP65
ON/Off cycles	>100000
Working conditions	-30 °C - 50 °C
Material	Aluminum+PC
Body Color	Black
Certification	ENEC CE RoHS
Type of light source	A
Warranty	5 Years

IP65 IK08 05